

level measurement

level switch NGS 250

features

- level switch for fluid types
- the ideal alternative unit for the swing level switch
- aseptic measuring point by process connection thread M12 for modulare welded sleeve- and process connection system
- EHEDG-conform, food safe material
- **starting an adjustment by PC not necessary**
- definated position of screwing

technical specifications

- connection head made of stainless steel 1.4305
- food tangent level stick made with lamination PFA P16501
- process connection G1/2" modulare system
- electrical connection with screwing or optional M12-plug
- protection class IP69K
- auxiliary supply 12...35VDC
- output signal active, max 50mA, short-circuit proof
- switching function full/empty by polarity of auxiliary supply
- temperature range 0...140°C process temperature for 30min
- high temperature design with neck tube optional
- temperature rang connection head -20°C to +80°C
- max. operating pressure 10bar
- optional with switching status LED

application areas

- fill level detection in cases and big pipelines
- dry running condition protection
- empty-/full announcement

product benefits

- aseptic sealing system
- food-safe materials (EHEDG-compliant)
- independence from the conductivity of the medium
- fast learning possible via teach-in button
- robust stainless steel head with protection class IP69K
- reliability even with adhesive and viscous media



NGS 250-5-A-1

full announcement

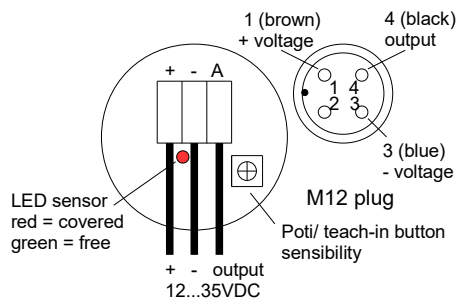

empty announcement

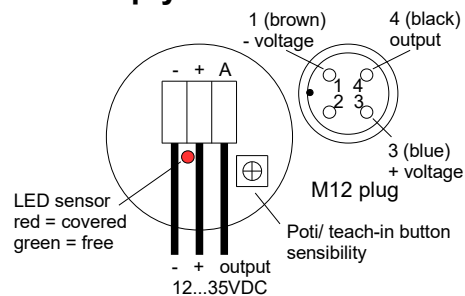

technical drawing

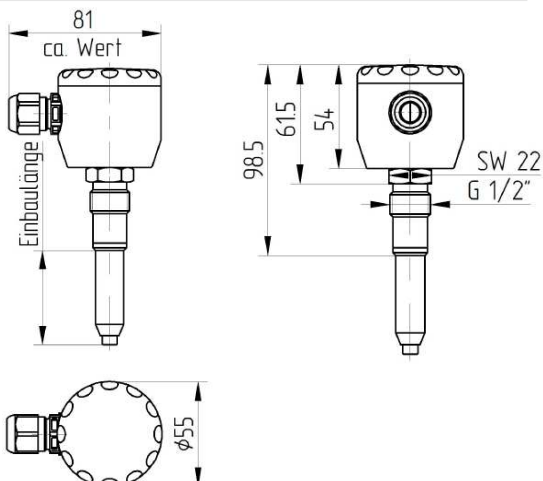

level measurement

order-code NGS 250...

order example: NGS 250-5-A-1

connection heads

- 5 stainless steel head standard with screwing
- 6 stainless steel head standard with M12-plug

design

- X switch-point at 19mm
- Y switch-point at 38mm
- A switch-point at 50mm
- B switch-point at 100mm
- C switch-point at 150mm
- D switch-point at 200mm

optional

- TI with teach-in
- 1 standard design
- 2 with extern switching status LED

accessories

welding sleeves

- 99-000191 KEM 150, welding sleeve, bullet, for G1/2" sealing system, diameter 35m, hygienic process adaption
- 99-000193 ZEM 150, welding sleeve, cylinder, for G1/2" sealing system, diameter 30mm, hygienic process adaptation

M12-connection wires

- 101090 connection cable M12 angled, 4-pole, 5m PVC cable, grey
- 101087 connection cable M12 straight, 4-pole, 5m PVC cable, grey

Other lengths available on request.

For more accessories, see accessories data sheet.