

## user manual resistance thermometers type WTR 350..., WTR 360..., WTR 390..., WTR 395...

### safety instructions !!!

#### intended use of the product

- The sensor has been designed exclusively for the intended use described here or in the datasheet and may only be used in this way.
- The technical specifications contained in these operating instructions must be observed.
- Improper handling or operation of the device outside of its technical specifications requires the device to be taken out of service immediately and an inspection by promesstec.
- When the device is transported from a cold into a warm environment, the formation of condensation may result in the device malfunctioning.
- Before putting it back into operation, wait for the device temperature and the room temperature to equalise.

*The manufacturer shall not be liable for claims of any type based on operation contrary to the intended use!!*

#### staff qualification

Improper handling can result in considerable personal injury and damage to equipment. The activities described in these operating instructions may only be carried out by skilled staff who have the appropriate qualifications. For installation and starting of the sensor, the relevant regulations and directives of the country and the norms must be observed. Especially during installation of the sensor, it is possible, depending on the use, to come into contact with aggressive media. The safety instructions must be observed. There will be danger to life if live parts are touched. Electrical installation and commissioning may only be carried out by qualified and skilled personnel.

#### special hazards

Residual media in and on dismantled devices can result in a risk to personnel, the environment and equipment. Sufficient precautionary measures must be taken here. Do not use the instruments in safety or emergency stop devices. Incorrect application or operation of the instrument can lead to injuries. Depending on the application, aggressive media with extreme temperatures and high pressure or vacuum may be present at the instrument in the event of a fault. We recommend installing and removing the device only at ambient temperature and in a pressureless mode.

#### hazards when operating the device

Our devices have a very high protection class when properly mounted and installed. When cleaning your system with high-pressure cleaners, steam cleaners etc., make sure that both the cover and the cable screw or M12 connector are not directly exposed to the pressure jet. If the temperature falls below the dew point, condensation may form in the connection chamber of the device. In such extreme applications, contact our sales and technical support before commissioning.

# temperature measurement

connection WTR 350, WTR 360, WTR 390, WTR 395 with screw connection

## clamp arrangement passive sensors

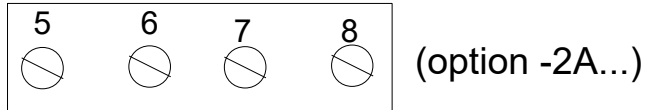
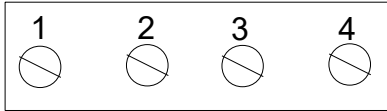

## clamp arrangement active sensors

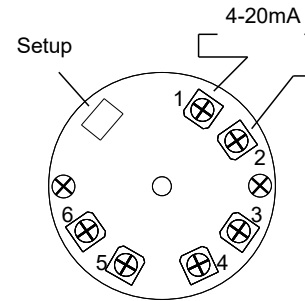

## connection passive sensors PT100 and PT1000

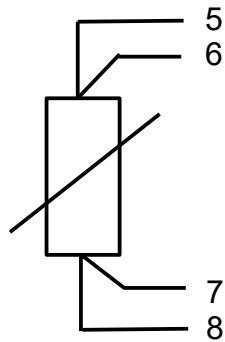
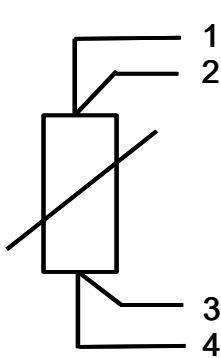

(option -2A...)

### *Important information:*

The sensor can be connected in 2, 3 or 4-wire technology.

## connection of active sensors with head transducer KMU

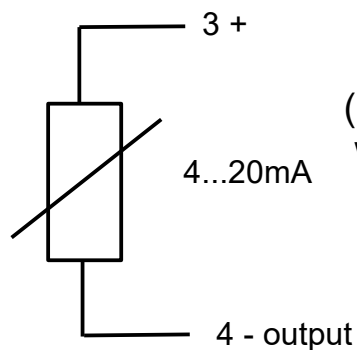
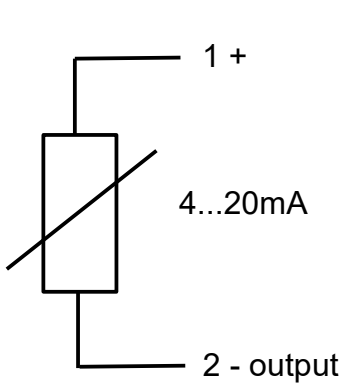

(option -2KMU, version with Wago clamps)

# temperature measurement

connection WTR 350, WTR 360, WTR 390, WTR 395 with M12 plug

electrical connection WTR 3... with M12 plug without head transducer

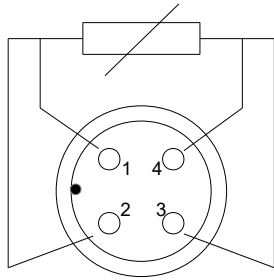

- 1 (brown)
- 2 (white)
- 3 (blue)
- 4 (black)

M12 plug with 1 x PT100 or PT1000

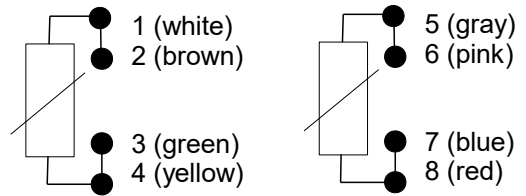
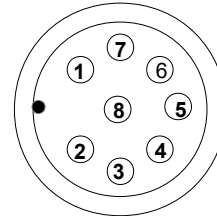

M12 plug (8-pole) with 2 x PT100 or PT1000

**important information:**

The sensor can be connected 2, 3 or 4-wire technology.

electrical connection WTR 3... with M12 plug and with head transducer KMU

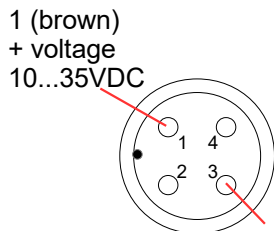

1 (brown)  
+ voltage  
10...35VDC

3 (blue)  
output 4...20mA

M12 plug with 1 x KMU

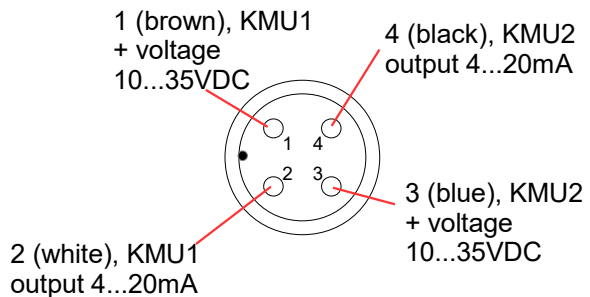

1 (brown), KMU1  
+ voltage  
10...35VDC

4 (black), KMU2  
output 4...20mA

2 (white), KMU1  
output 4...20mA

3 (blue), KMU2  
+ voltage  
10...35VDC

M12 plug with 2 x KMU

The optional KMU transducer is adjustable with the PXU01 software and the corresponding programming adapter can be set. The user manual for the software is included in the programming kit.

**You can find the datasheets and the user manual on our homepage.**

## temperature measurement

### mounting instructions !!!

#### mechanical installation

- Only use promesstec welding sleeves and process connections for the adaptation in your process. This is the only way we can guarantee you a clean and aseptic measuring point.
- Our welding sleeves are provided with a marking. When properly installed, this is the position of the cable gland or M12 connector. You will find the welding instructions on our homepage under "technical information".
- The sensor seals with its PEEK ring (WTR 390 und WTR 395) or the stainless steel surface (WTR 360, WTR 390) on the sealing surface of the welding sleeve. Observe the **max. torque of 15-20Nm**. Otherwise, the sealing surface will be deformed.
- Never use insulating sealants such as Teflon tape or similar when mounting the sensor, as this could cause the aseptic of the measuring point to be lost.

#### electrical mounting

- Install the sensor in your process before the electrical mounting. In this way, you prevent coiling of the cable when mounting the measuring point.
- Screw the M12 socket onto the connector on the promesstec sensor by hand. The mounting is done without tools.
- When mounting the connection cable, ensure that both components are firmly and positively connected. For the permissible tightening torque, refer to the datasheet of the respective connection cable.

### important information !!!

#### return and repair

The promesstec sensor have a modular design. This allows us to repair and overhaul defective devices. To do this, send the device to promesstec. You will find a return form with the information to be provided on our homepage under „technical information“.

#### disposal of the devices

Dispose of devices, components and packaging in an environmentally friendly manner in accordance with the waste treatment and disposal regulations typical for the country. Pay attention to waste separation and the recycling of high-quality materials such as stainless steel, etc.

#### further documentation

These operating manual and the datasheets can be found as a file on our homepage under the respective devices. The documentation is available in German as well as in English. Other languages on request. Additional information such as characteristic curves of temperature sensors etc. can be found on our homepage under

