

User manual

Level device

NVG 200



Version 2.1.1

Content

1. General.....	3
1.1 Description measuring principle.....	3
1.2 Drawings, shortcut.....	3
2. Transport, Packaging, Storage.....	4
2.1 Transport.....	4
2.2 Packaging.....	4
2.3 Storage.....	4
3. Safety instructions.....	4
3.1 Intended use of the product.....	4
3.2 Stuff qualification.....	5
3.3 Special hazards.....	5
4. Starting operation.....	6
4.1 Connection - 230VAC/24VAC version with relay output.....	6
4.2 Connection - 24VDC version with relay output.....	6
4.3 Connection - 24VDC version with electronic output PNP 24VDC.....	7
4.4 Installation.....	7
4.5 Inverting the switching logic.....	8
4.6 Application examples.....	8
5. Technical specifications.....	9
6. Dimensions.....	9
7. Dismounting, Return, Cleaning, Disposal.....	10
7.1 Dismounting.....	10
7.2 Return.....	10
7.3 Cleaning.....	10
7.4 Disposal.....	10

Level device NVG 200

1. General

1.1 Description measuring principle

The NVG 200 level device is used for conductive level monitoring in electrically conductive liquids. A simple level control can be implemented on channel 1 using a min. and max. electrode. A pump or valve can be controlled directly via a potential-free changeover contact. A switching time delay of 0.5 to 10 seconds can be set. Channel 2 works independently of the first and can be used either as an additional full or empty detector. For example, overflow protection or dry-running protection can be implemented.

- Compact design (top-hat rail mounting, 22.5mm width)
- 2 separate functional channels
- 2 potential-free changers
- Adjustable sensitivity range (1...100 k)
- Adjustable switching time delay (0.5...10 sec)
- Direct voltage-free electrode voltage

1.2 Drawings, shortcut



Warning!

A non-observance can cause injuries to persons and/or the demolition of the device. There can be a dangerous to life.



Attention!

A non-observance can cause a faulty operation of the device or lead to property damage.



Information!

A non-observance can have influence on the operation of the device or cause unintentional reactions of the device.



Danger!

When not observing the safety instructions, there is a risk of serious or fatal injuries caused by electrical power.



Warning!

Possibly a dangerous situation can occur, which results in burns because of hot surfaces or liquids, if not avoided.

2. Transport, Packaging, Storage

2.1 Transport

Check the instrument for any damage that may have been caused during transportation. If, report them immediately. The temperature during transportation and storage of the meter must be within the range of -10 °C to 50 °C.

2.2 Packaging

Do not remove packaging until just before mounting. Keep the packaging as it will provide optimum protection during transport (e.g. change in installation site, sending back).

2.3 Storage

For longer term storage avoid the following influences:

1. Direct sunlight or proximity to hot objects
2. Mechanical vibration, mechanical shock (putting it hard down)
3. Soot, vapour, dust and corrosive gases

If possible store the device in its original package or an equivalent one

3. Safety instructions



More important safety instructions can be found in the individual chapters.

3.1 Intended use of the product

The sensor has been designed and built solely for the intended use described here and may only be used accordingly. The technical specifications contained in these operating instructions must be observed. Improper handling or operation of the instrument outside of its technical specifications requires the instrument to be taken out of service immediately and an inspection by the manufacturer. When the instrument is transported from a cold into a warm environment, the formation of condensation may result in the instrument malfunctioning. Before putting it back into operation, wait for the instrument temperature and the room temperature to equalise. The manufacturer shall not be liable for claims of any type based on operation contrary to the intended use.

3.2 Stuff qualification



Warnung

Improper handling can result in considerable injury and damage to equipment. The activities described in these operating instructions may only be carried out by skilled staff who have the qualifications described below. Keep unqualified staff away from hazardous areas.

For installation and starting of the flow-meter the staff has to be familiar with the relevant regulations and directives of the country and must have the qualification required. They must have knowledge on measurement and control technology, have to be acquainted with electric circuits, are capable of carrying out the work described and can independently recognize potential hazards. Depending on the operation conditions of the application they have to have the corresponding knowledge, e.g. of aggressive media.

3.3 Special hazards



Warnung

For hazardous media such as oxygen, acetylene, flammable or toxic gases or liquids, refrigeration plants, compressors, etc., in addition to all standard regulations, the appropriate existing codes or regulations must also be followed. **If you do not observe the appropriate regulation, serious injuries and/or damage can occur!**



Warnung

A protection from electrostatic discharge (ESD) is required. The proper use of grounded work surfaces and personal wrist straps is required when working with exposed circuitry (PCB, printed circuit boards), in order to prevent static discharge from damaging sensitive electronic components.



Gefahr

There is a danger of death caused by electric current. Upon contact with life parts, there is a direct danger of death. Electrical instruments may only be installed and connected by skilled electrical personnel. Operation using a defective power supply unit (e.g. short circuit from the mains voltage to the voltage output) can result in life-threatening voltages at the instrument.



Warnung

Residual media in dismantled instruments can result in a risk to personnel, the environment and equipment. Take sufficient precautionary measures. Do not use this instrument in safety or Emergency Stop devices. Incorrect use of the instrument can result in injury. Should a failure occur, aggressive media with extremely high temperature and under high pressure or vacuum may be present at the instrument.

4. Starting operation

4.1 Connection - 230VAC/24VAC version with relay output

- 1 supply voltage 230V L / 24VAC
- 2 supply voltage 230V N / 24VAC
- 3 not documented
- 4 inversion level function channel 1
(bridge on KI.8 M)

- 5 electrode channel 1 above
- 6 electrode channel 1 below
- 7 electrode channel 2
- 8 mass (container wall)

- 9 relay K1 normally open
- 10 relay K1
- 11 relay K1 normally closed
- 12 not documented

- 13 relay K2 normally open
- 14 relay K2
- 15 relay K2 normally closed
- 16 not documented

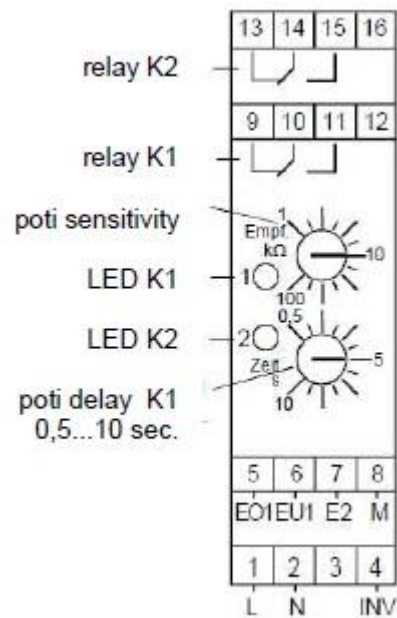

4.2 Connection - 24VDC version with relay output

- 1 supply voltage 24VDC +
- 2 supply voltage 24VDC -
- 3 not documented
- 4 inversion level function channel 1
(bridge on KI.8 M)

- 5 electrode channel 1 above
- 6 electrode channel 1 below
- 7 electrode channel 2
- 8 mass (container wall)

- 9 relay K1 normally open
- 10 relay K1
- 11 relay K1 normally closed
- 12 not documented

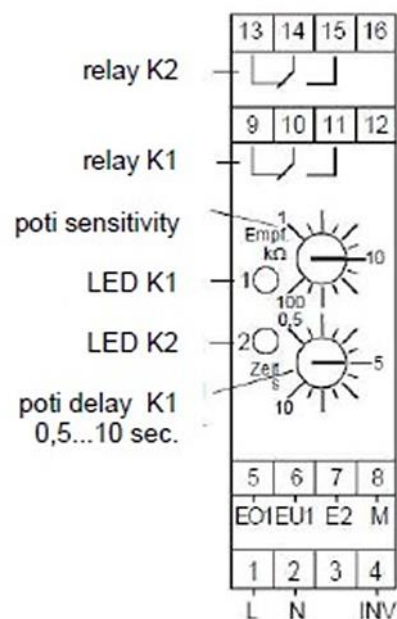

- 13 relay K2 normally open
- 14 relay K2
- 15 relay K2 normally closed
- 16 not documented

4.3 Connection - 24VDC version with electronic output PNP 24VDC

- 1 supply voltage 24VDC +
- 2 supply voltage 24VDC -
- 3 not documented
- 4 inversion level function channel 1
(bridge on KI.8 M)

- 5 electrode channel 1 above
- 6 electrode channel 1 below
- 7 electrode channel 2
- 8 mass (container wall)

- 9 not documented
- 10 not documented
- 11 not documented
- 12 PNP output channel 1

- 13 not documented
- 14 not documented
- 15 not documented
- 16 PNP output channel 2

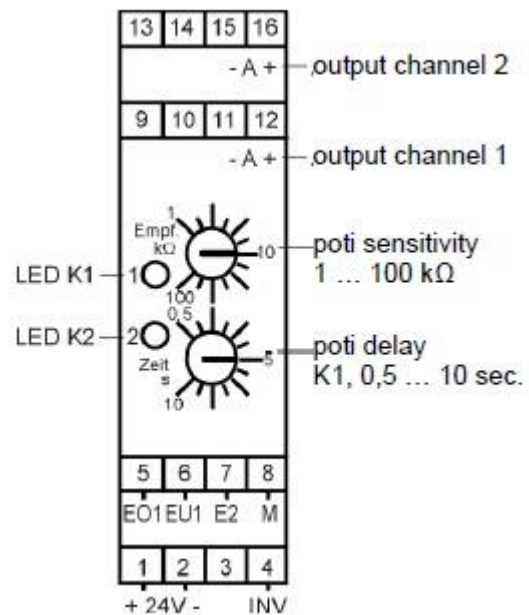

4.4 Installation

! Before switching on the device, you should check whether the sensor has been installed and wired correctly.

1. Connect the device according to the connection diagram.
2. Potentiometer time delay and potentiometer sensitivity to the left stop (minimum).
3. Increase the filling level until the electrode EO1 is safely covered
3. Turn the sensitivity potentiometer to the right (clockwise) until the relay switches safely or the status LED for channel 1 switches from green to red.
4. If necessary, set the desired delay time using the time delay potentiometer.
5. The comparison is finished.

4.5 Inverting the switching logic

Both the first and second channels can be inverted independently. In contrast to an NVG with PNP outputs, with an NVG with relay outputs it is also possible to use the NC contact of the changeover relay in addition to the NO.

Channel 1 can be inverted via connection terminal 4 (see connection). The filling level can be regulated either by emptying or filling.

Channel 2 is inverted via a jumper inside the NVG 200. This can be used either as a full or empty detector (overflow or dry running protection).

ATTENTION: To invert channel 2, the NVG 200 must be opened. This may only be carried out in a de-energized state and only by qualified personnel!

4.6 Application examples

Level control in the container with additional dry-running protection

- A container is continuously filled. If the level of the medium rises to the electrode EO1, the pump is switched on and the container is emptied until the electrode EU1 is reached.
- The pump is switched off.
- A dry-running electrode on E2 prevents the pump from running dry in the event of a fault.

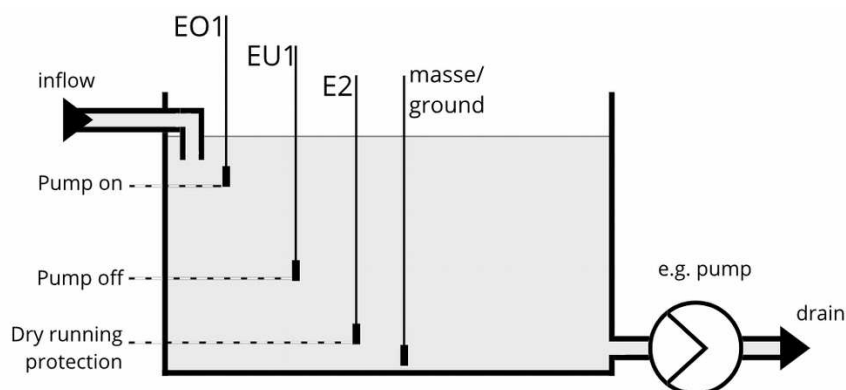

Inverted level control in the container with additional overflow protection

- A container is continuously emptied. If the level of the medium drops below the EU1 electrode, the valve is opened and the container is filled until the EO1 electrode is reached.
- The valve is closed.
- An overflow electrode on E2 prevents the container from overflowing in the event of a fault.

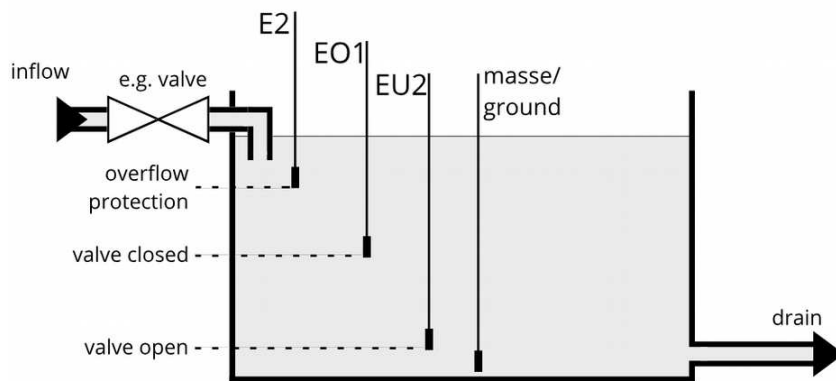

5. Technical specifications

Function channel 1	level control invertible (full/empty) switching delay adjustable 0.5...10 sec.
Function channel 2	full/empty message without delay
Sensitivity	1...100 kOhm adjustable (pot)
Outputs	2 potential-free changeover contacts (250V, 3A)
Electrode voltage	max. 5V AC, DC voltage-free
Supply voltage	230V/50Hz, max. 3 VA 24VDC (optional 24V/50Hz, 110V/60Hz)
Operating temperature	-10...+55 °C
Housing dimensions	22.5x99x115 mm (WxHxD)
Protection class	IP20

6. Dimensions

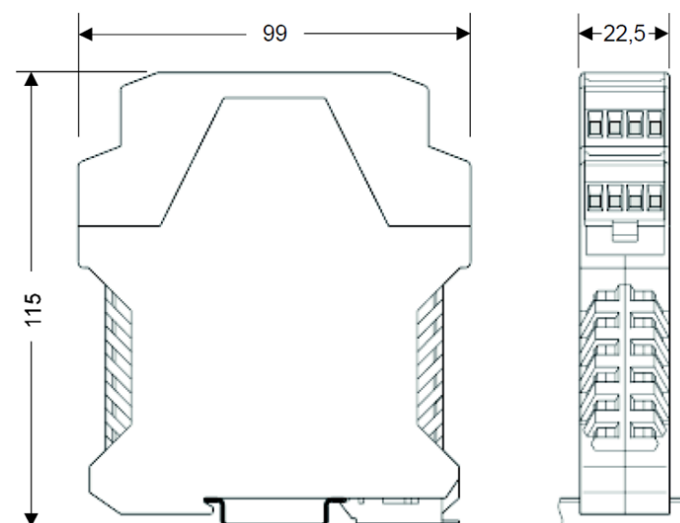

7. Dismounting, Return, Cleaning, Disposal

7.1 Dismounting



Residual media in dismantled instruments can result in a risk of personnel, the environment and equipment. Take sufficient precautionary measures.



There is a risk of burns. Let the instrument cool down sufficiently before dismantling. During dismantling there is a risk of dangerously hot pressure media escaping.

Only disconnect the resistance thermometer once the system has been depressurised.

7.2 Return



When returning the instrument, use the original packaging or a suitable package.

To avoid a damage, use for example antistatic plastic film, shock-absorbent material, a marking as highly sensitive measuring instrument.

7.3 Cleaning



Before cleaning the instrument disconnect the electrical connection. Clean the instrument with a moist cloth. Electrical connections must not come into contact with moisture. Wash or clean the dismantled instrument before returning it in order to protect personnel and the environment from exposure to residual media.

Residual media in dismantled instruments can result in a risk to persons, the environment and equipment. Take sufficient precautionary measures.

7.4 Disposal



Dispose instrument components and packaging materials in accordance with the respective waste treatment and disposal regulations of the region or country to which the sensor is supplied.