

temperature measurement

resistance thermometer WTR 450

features

- modular resistance thermometer for food industry
- adaptable with sleeve socket and process connection thread (see accessories)
- process connection thread G1/2"
- short reaction time without reduced measuring point
- temperature resistance PT100 directly constructed in protective fitting
- electrical connection with M12-plug (connections see accessories)
- optional with programmable measuring transducer (same program kit like at KMU100), output 4-20mA 2-wire
- specials on request



WTR 450-9-A-1A-PMU

technical specifications

- protective fitting made of stainless steel V4A 1.4404 (316L) resp. V4A 1.4571
- diameter 6 x 1 mm, other diameters on request
- temperature range: -50 °C to +150 °C (extended ranges on request)
- power supply at option measuring transducer 10...35VDC



WTR 450-9-A-1A

product benefits

With our compact WTR 450 you are able to measure temperatures in the food industry under ideal space utilization. The sensor has a sealing cone below the connection thread, which is aseptically adapted with the help of our welding sleeve (ZEM 150 or KEM 150). You will benefit from the very high quality and durability of the sensor, which is achieved by using high-quality materials. Even in rough industrial environments this sensor can be used without any problems.

pin assignment

1 (brown)
 + voltage
 10...35VDC

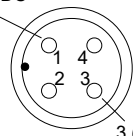

M12 plug with PMU

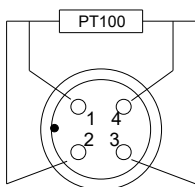

M12 plug (only PT100)

1 (brown)
 2 (white)
 3 (blue)
 4 (black)

technical drawing

WTR 450

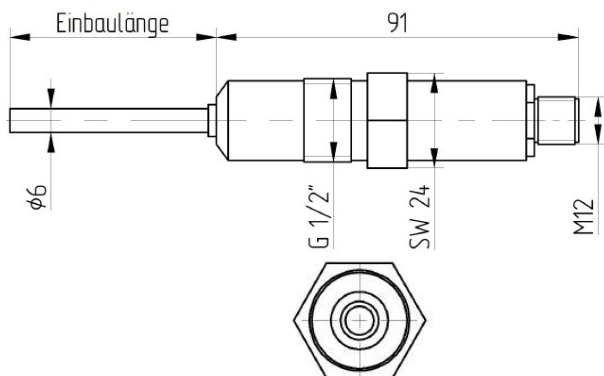

WTR 450 with PMU

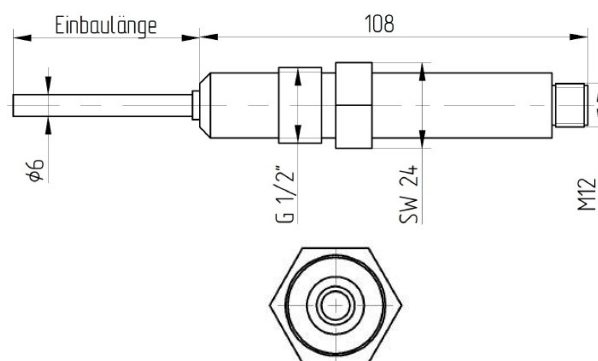

temperature measurement

order-code WTR 450...

order example: WTR 450-9-A-1A-PMU (0-100 °C)

kind of connection

-9 compact construction, directly with M12-plug, protection class IP69K

mounting length

-A 50 mm mounting length
-B 100 mm mounting length
-C 150 mm mounting length
-D 200 mm mounting length
-E 250 mm mounting length
-F 300 mm mounting length
-K mounting length on customer's wish (please specify length)

type of sensor and tolerance

-1A 1xPT100 class A
-KX other types of sensor and tolerance on customer's request

tapered measuring point

-V0 (without description) without taper
-V3 tapered to 3 mm
-V4 tapered to 4 mm

optional

-PMU with programmable measuring transducer (temperature ranges on request on preadjustment please specify)

accessories

welding sleeves

-99-000191 KEM 150, welding sleeve, bullet, for G1/2" sealing system, diameter 35mm, hygienic process adaption
-99-000193 ZEM 150, welding sleeve, cylinder, for G1/2" sealing system, diameter 30mm, hygienic process adaptation

M12-connection wires

-101090 connection cable M12 angled, 4-pole, 5m PVC cable, grey
-101087 connection cable M12 straight, 4-pole, 5m PVC cable, grey