

temperature measurement

resistance thermometer WTR 350

features

- modular resistance thermometer for food industry
- adaptable with sleeve socket and process connection thread (see accessories)
- connection head made of stainless steel
- available with tapered measuring point
- protective fitting pressed closed to connection head
- temperature resistance PT100 directly constructed in protective fitting
- electrical connection on board (clamps) or programmable measuring transducer
- specials on request



WTR 350-5-B-1A-V0-KMU

technical specifications

- protective fitting made of stainless steel V4A 1.4571
- diameter 6 mm
- connection thread for sleeve socket and process connection threads G 1/2"
- temperature ranges: -50 °C to +200 °C (extended ranges on customer's request)

product benefits

The WTR 350 is a temperature sensor for the food industry. The sensor has a metal sealing cone below the connection thread. Due to the modular process connection system it can be used in aseptic welding sleeves as well as with different standardized process connections. High-quality materials additionally give this sensor a very high durability.

technical drawing

stainless steel head

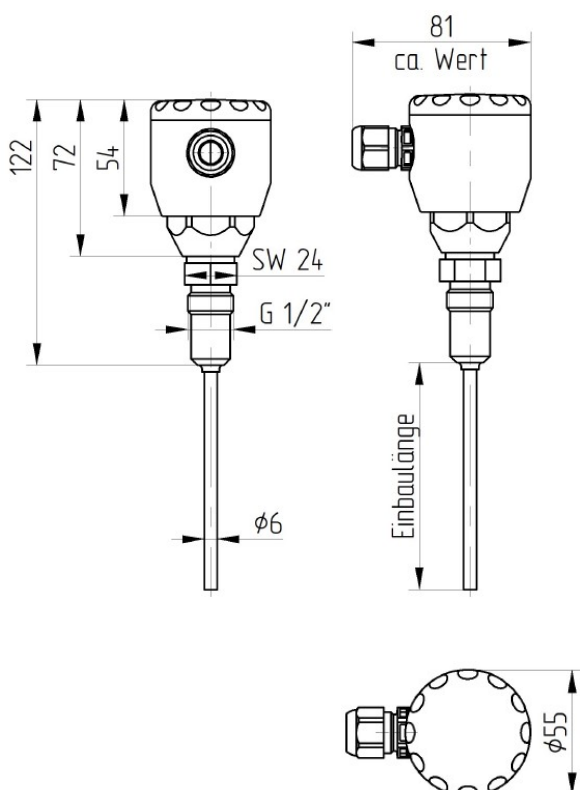

temperature measurement

order-code WTR 350...

order example: WTR 350-5-A-2A-V3-KMU (0-100 °C)

connection heads

- 5 stainless steel head standard with screw cap, with screwing, protection class IP69K
- 6 stainless steel head standard with screw cap, with M12-plug, protection class IP69K

mounting length

- A 50 mm mounting length
- B 100 mm mounting length
- C 150 mm mounting length
- D 200 mm mounting length
- E 250 mm mounting length
- F 300 mm mounting length
- G 350 mm mounting length
- H 400 mm mounting length
- K mounting length on customer's request (please specify length)

type of sensor and tolerance

- 1A 1xPT100 class A
- 2A 2xPT100 class A
- 1C 1xPT100 1/3 DIN
- 2C 2xPT100 1/3 DIN
- KX types of sensor and tolerance on customer's request

tapered measuring point

- VO without taper
- V3 tapered to 3 mm
- V4 tapered to 4 mm

optional

- KMU with programmable measuring transducer (temperature range on request on preadjustment please specify)

accessories

welding sleeves

- 99-000191 KEM 150, welding sleeve, bullet, for G1/2" sealing system, diameter 35m, hygienic process adaption
- 99-000193 ZEM 150, welding sleeve, cylinder, for G1/2" sealing system, diameter 30mm, hygienic process adaptation

Further accessories can be found under accessories.

M12-connection wires

- 101090 connection cable M12 angled, 4-pole, 5m PVC cable, grey
- 101087 connection cable M12 straight, 4-pole, 5m PVC cable, grey